



FH94

BACK OF HOUSE



The Broiler Built By Combining 45 Years of BK Experience & Innovation

In 1974, Nieco began developing custom solutions to the most common challenges in BK kitchens. We are proud to introduce the next generation of Nieco's automatic flame broilers for Burger King. The FH94 model line combines our decades of experience and innovation, the equipment-longevity of the JF series, and favorite features of classic MPB models, for an all-new broiler that keeps the Heart of your BK kitchen beating stronger than ever.

FEATURES

- Large capacity cooking chamber — 15% larger cook zone for higher volume
- Nieco BroilVection™ technology for faster cook times, quicker service and signature flame-broiled flavor
- New "Self-cleaning" BroilVection™ upper and lower burner system simplifies daily cleaning requirements. Clean lower burner weekly and upper system monthly.
- Improved heat-balance and grease-management system controls flaming
- Touch Screen Controller for easy operation, IoT Capable for new Connected Kitchens

HEAT OPTIONS

- Natural Gas or LPG

ACCESSORIES

- Quick Disconnect Gas Hose
- Kitchen Theater Look Kit (2020)
- Preventative Maintenance Kit
- Daily Time Savings Kit
- Spare Parts Kits: Critical, Motor & Blower, Touch Screen Controls, PTFE Kit



The Heart of Your BK Kitchen

FH94 FLAME BROILER BACK OF HOUSE MODEL

Back of House Model standard trim includes wheeled stand with shelf, PHU Holder, and Incendalyst™ Emission Control Device





FH94

BACK OF HOUSE



The Broiler Built By Combining 45 Years of BK Experience & Innovation

DIMENSIONS (WITH BACK OF HOUSE STANDARD)

	Inches	mm
Width	45.1	1146
Length	42.0	1068
Height	65.8	1671 (with Stand and Incendalyst™)

ENERGY (FACTORY RATED)

Gas Models:

- Natural Gas or LPG (mixed gas call factory)
- Average Usage: 96,000 BTU/hour
- Connection Size: 3/4" NPT
- Domestic: 120V, 11A
- Export: 220V, 6A

WARRANTY

One-year parts and labor. All Nieco equipment is backed by a worldwide sales and service network, with local parts inventories and 24-hour emergency service.

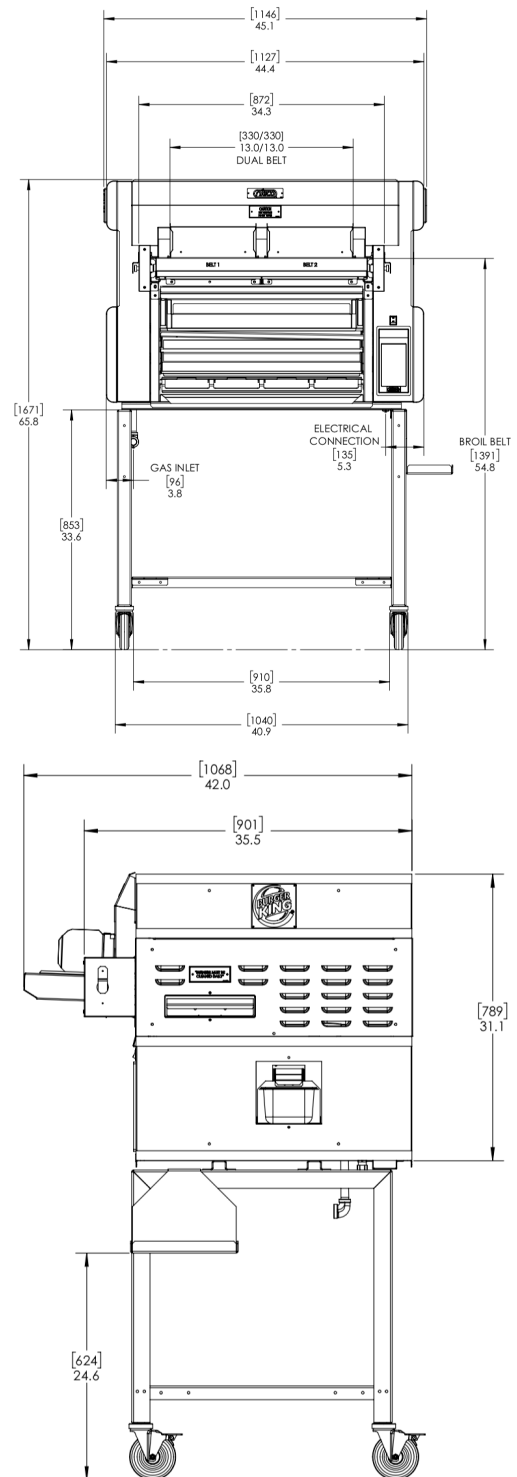

APPROVALS



Intertek

Call us today at **800-643-2656** or e-mail us at **sales@nieco.com**

Revised 10.15.19